

WBV370NX

Kit A11/85

Numatic

numatic.com

OUT OF
THE BOX
Instructions

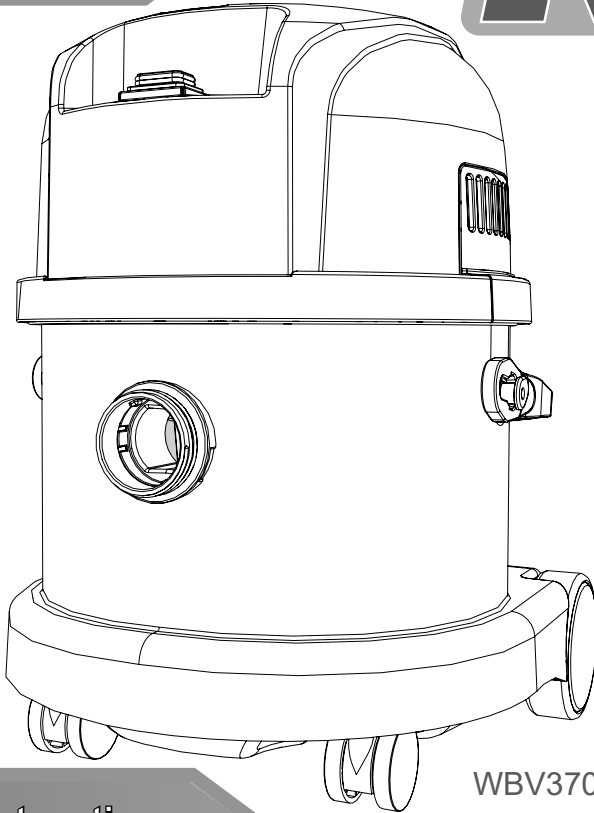

WBV370NX

Original Instructions

CAUTION,
Read the Instructions before using the machine.

Edgar Edmondson Pty Ltd

Head Office
PO Box 198
Marrickville
NSW 1475
AUSTRALIA

Delivery and Shipping Address
18 Garden St
Marrickville
NSW 2204
AUSTRALIA

Office Number: 1800 BUY MOP
Fax Number: +61 (0)2 9519 9223
E-Mail: orders@edmondson.net.au

ABN: 27 000 450 144

Edco

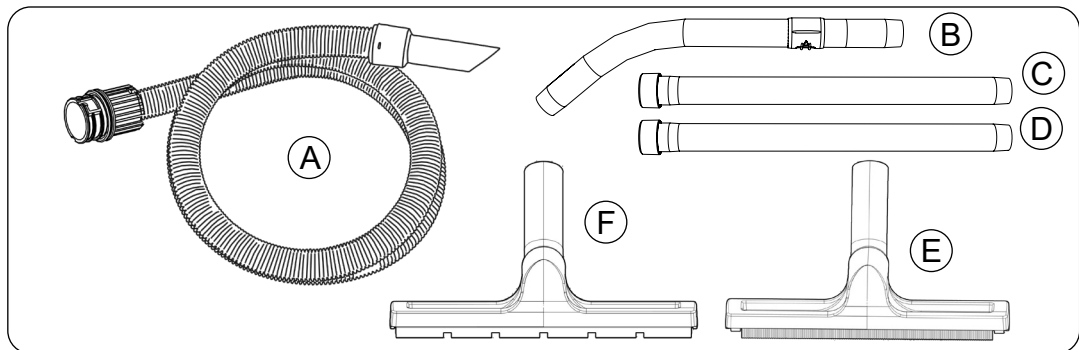

NX300 Battery Fitting

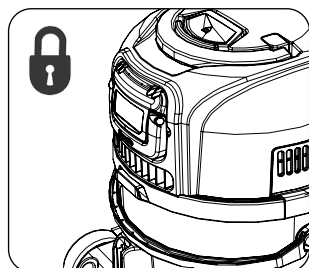
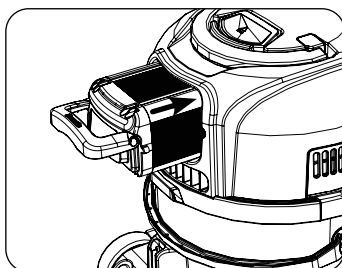
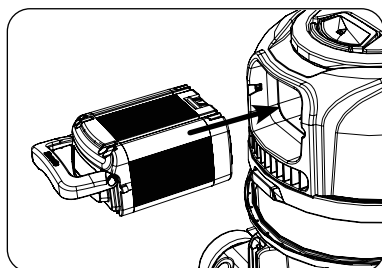

Wet - Assembling the machine for use

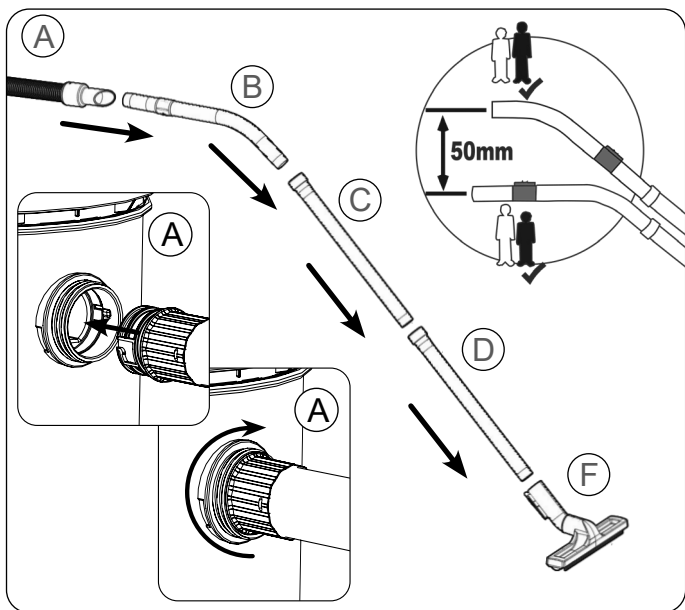
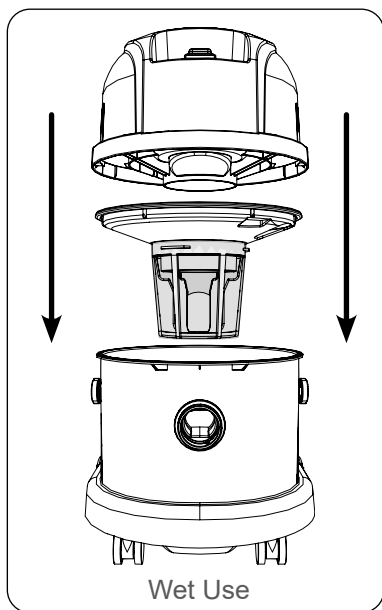

Wet - Emptying your machine

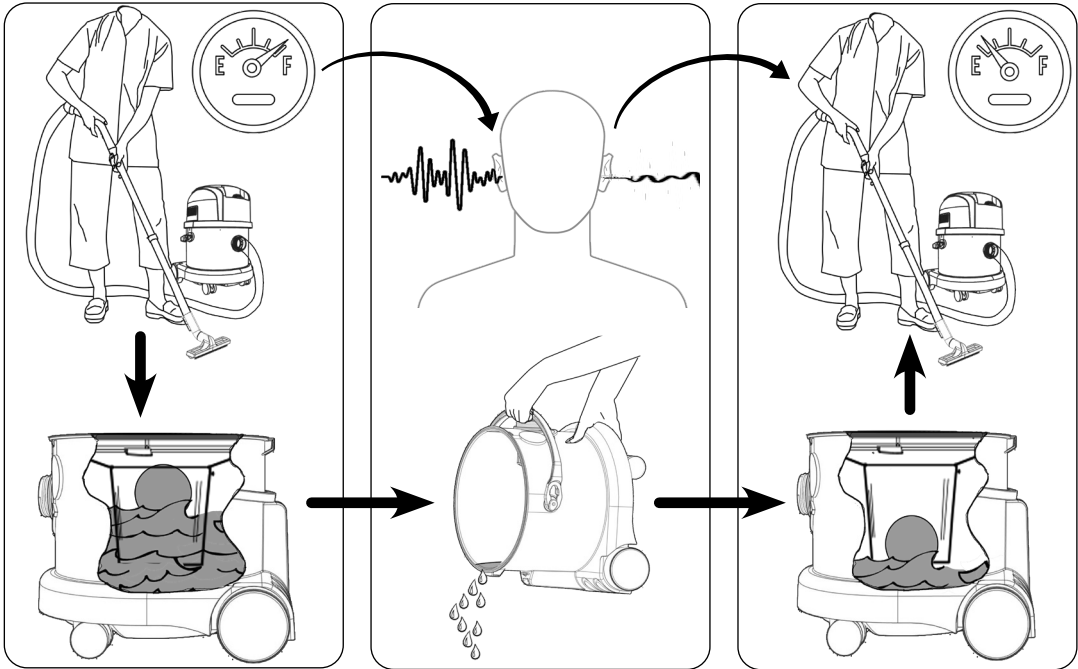

Wet - Using the machine

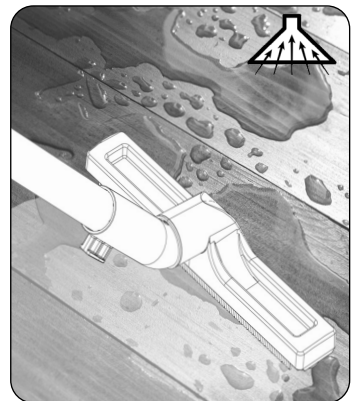
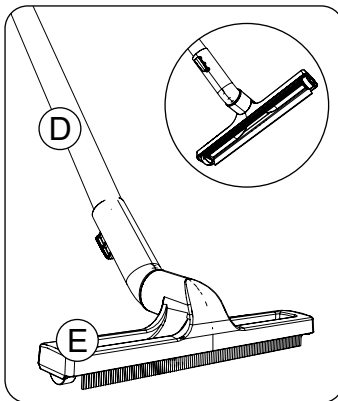
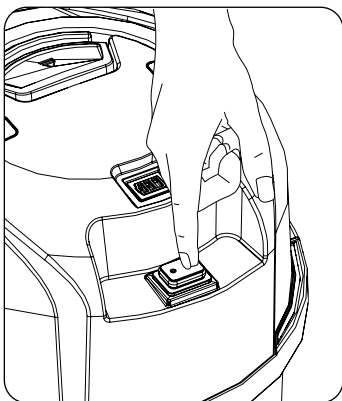

Cleaning your machine

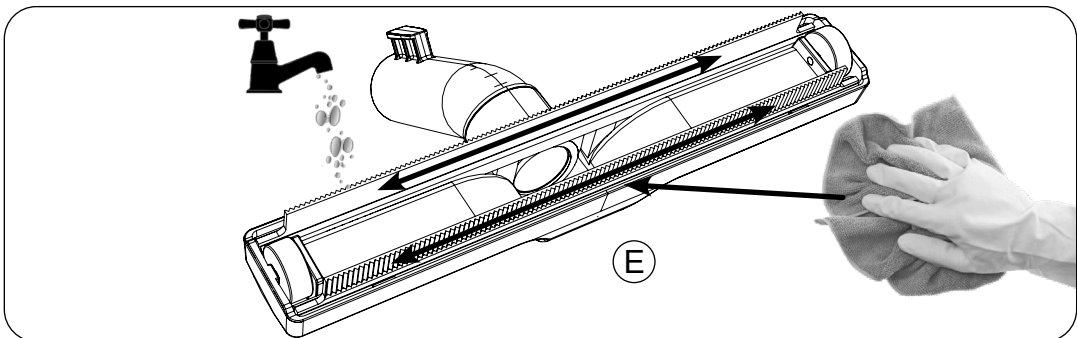
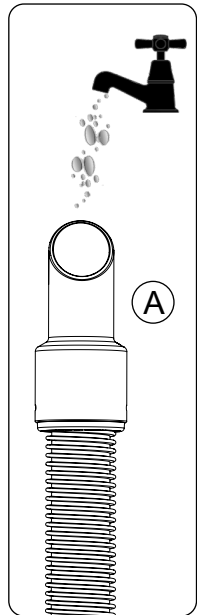
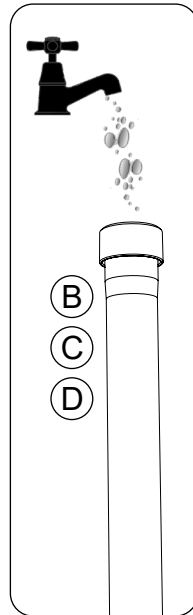
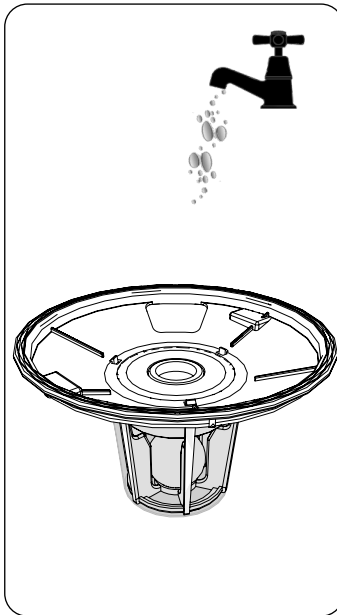
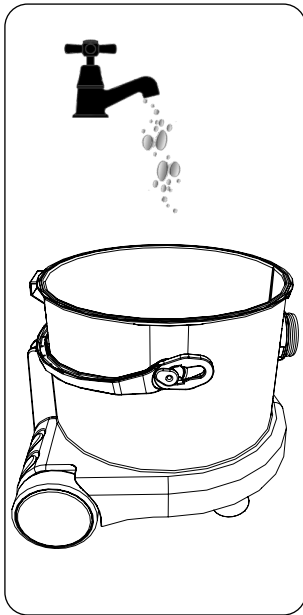
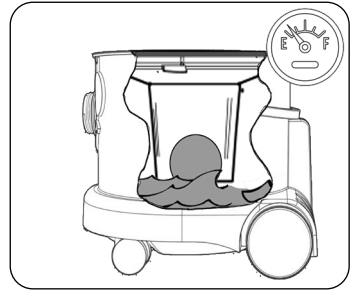
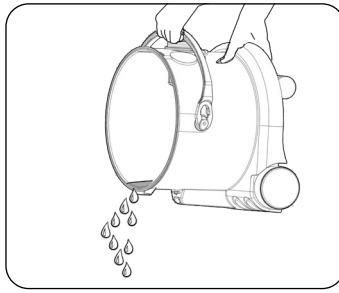
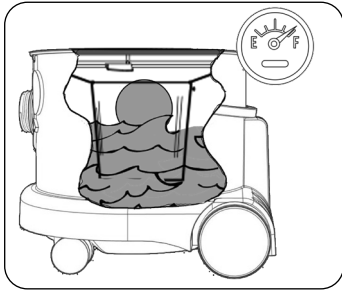

Dry - Assembling the machine for use

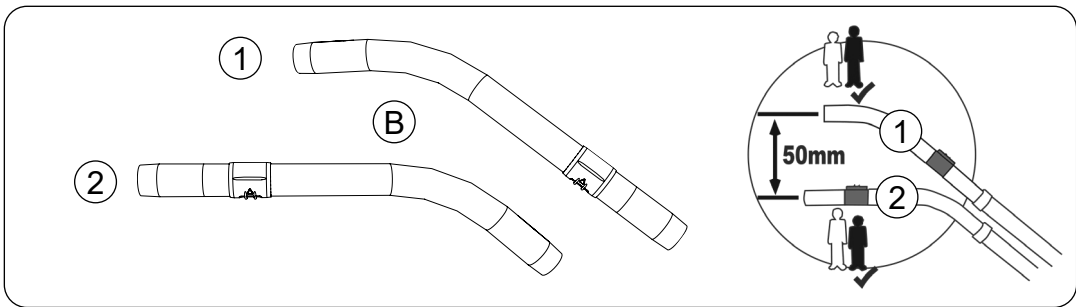
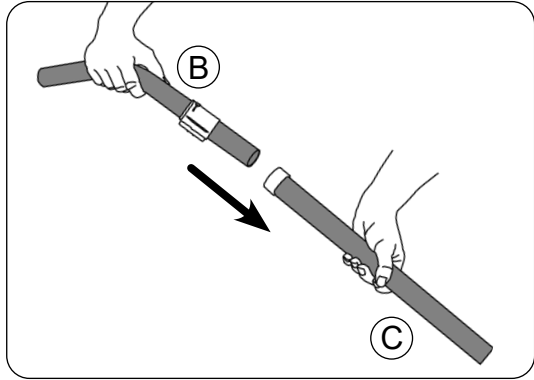
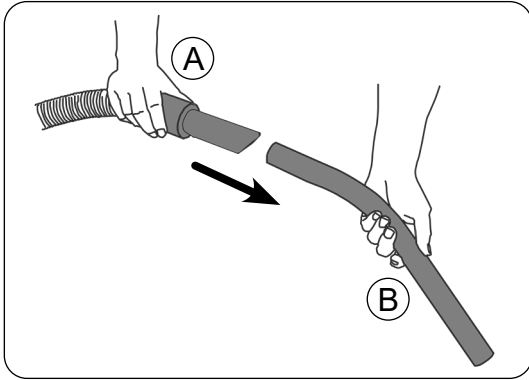
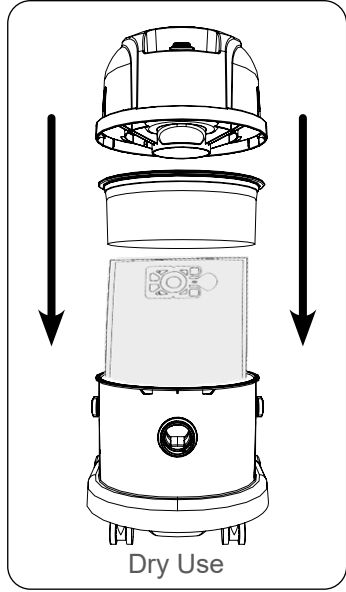
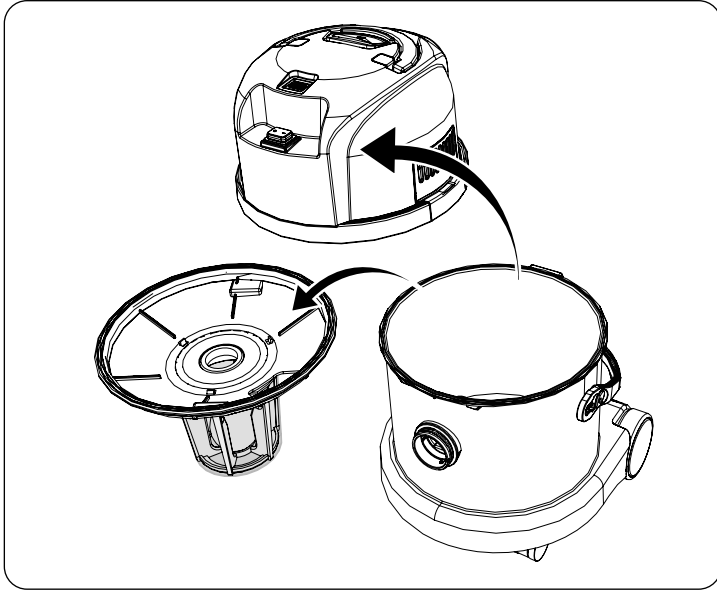

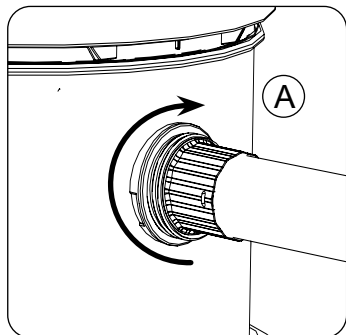
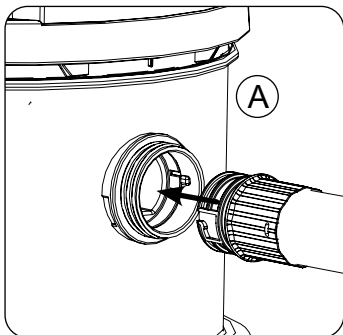
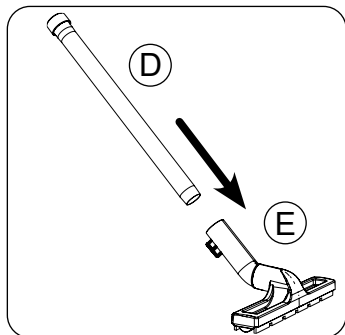

Dry - Using the machine

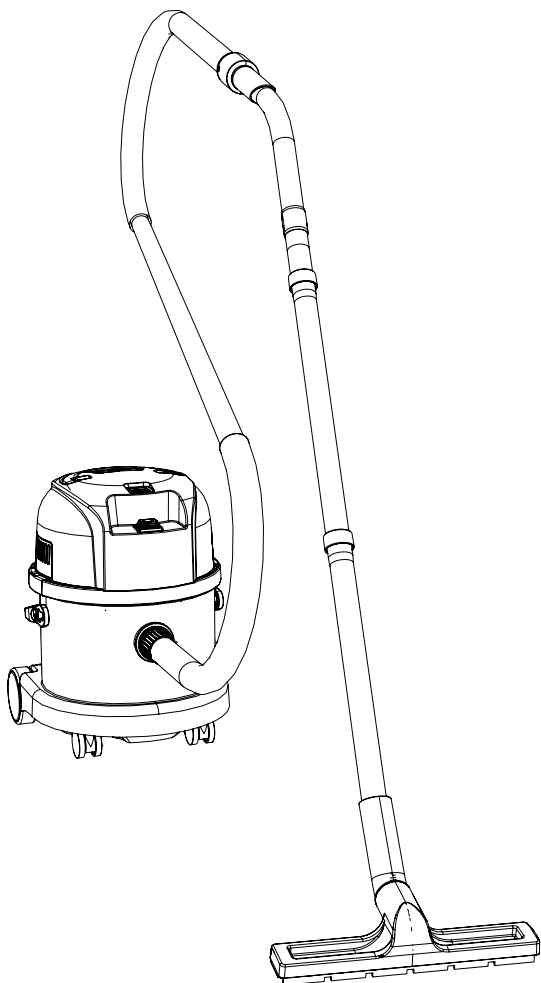
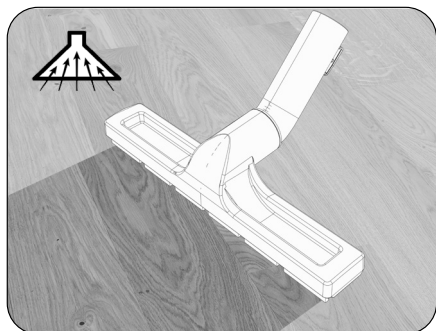
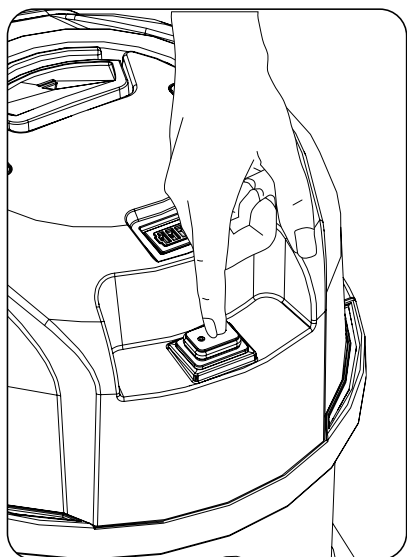

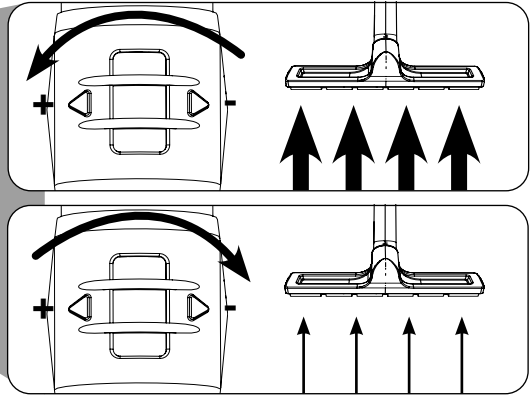
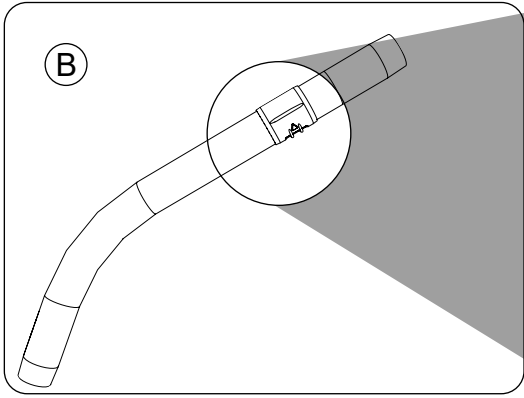

Floor Tool Tidy

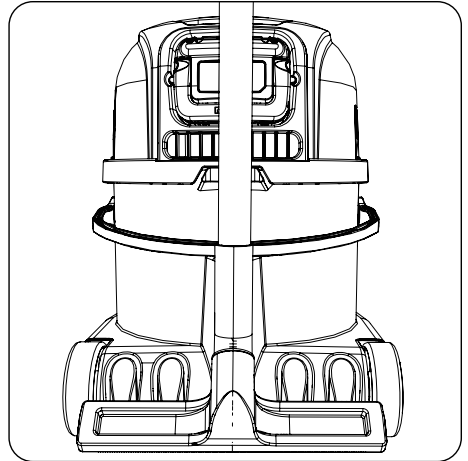
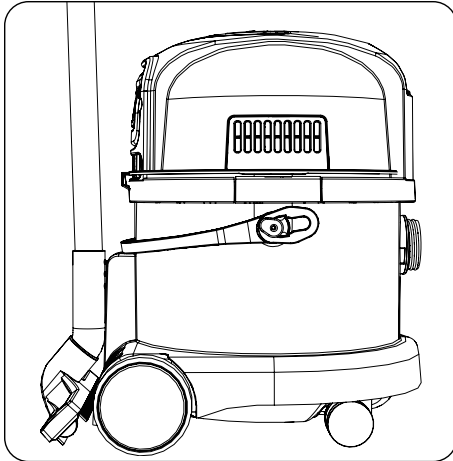
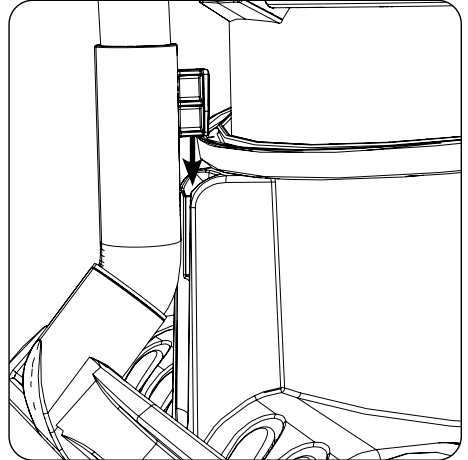
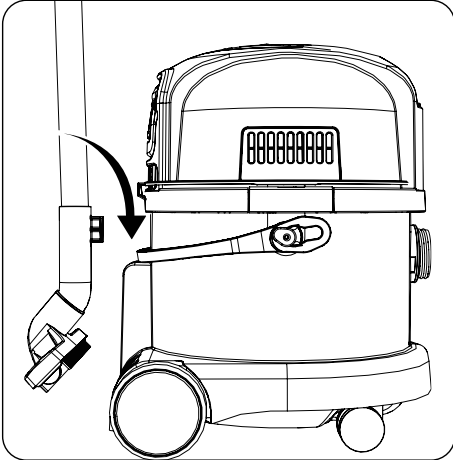

Dry - Emptying your Hepa Flo Bag

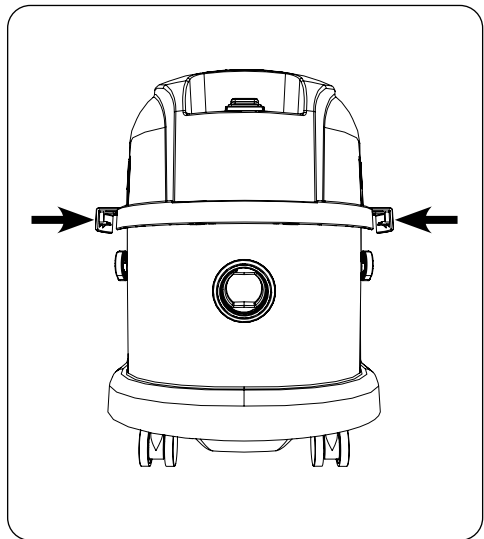
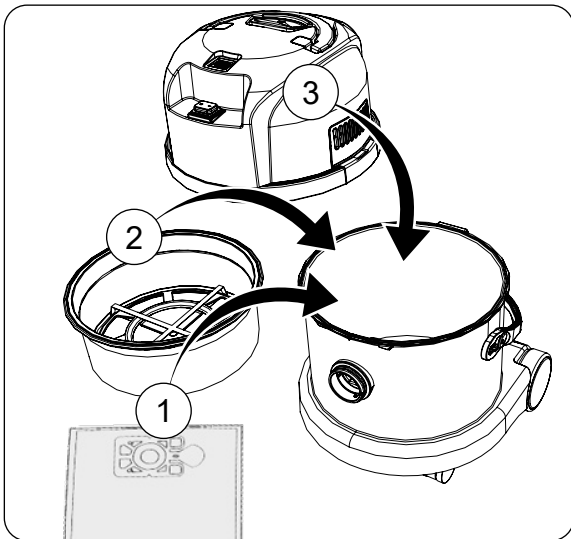
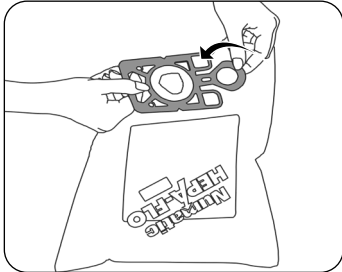
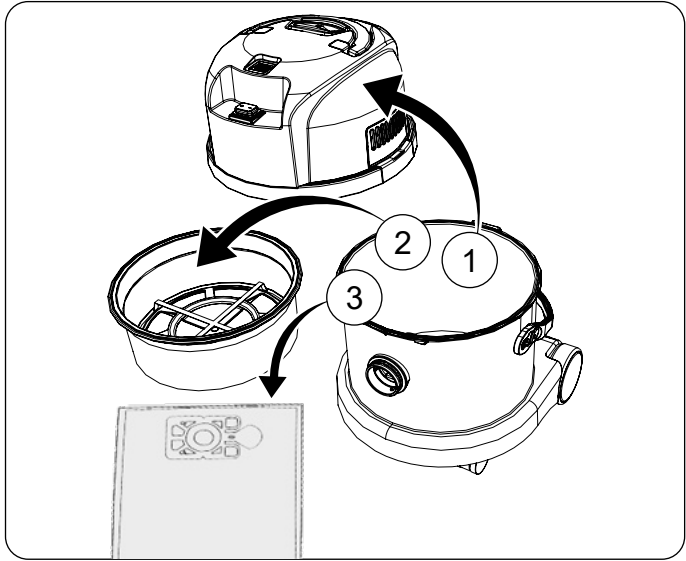
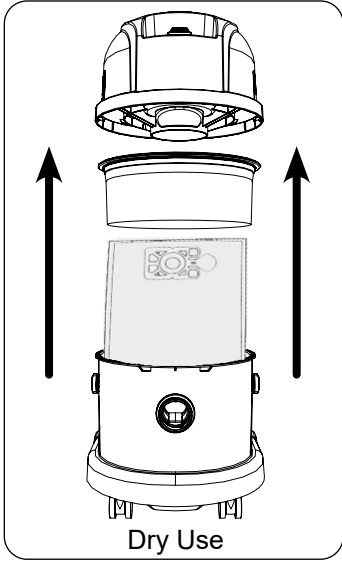

Battery Status

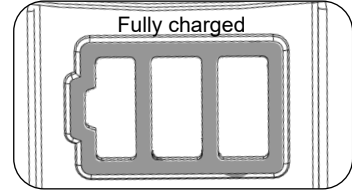
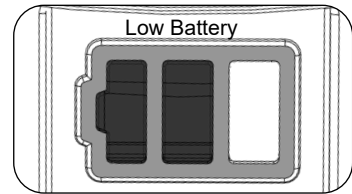
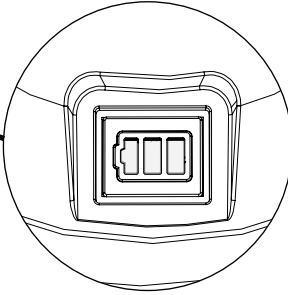
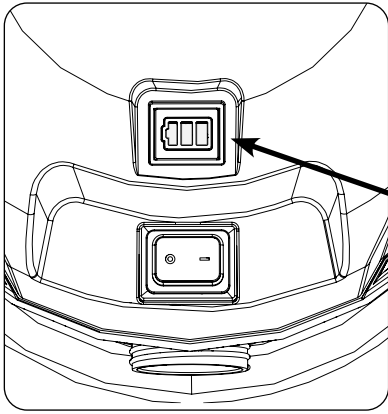

Charging your battery

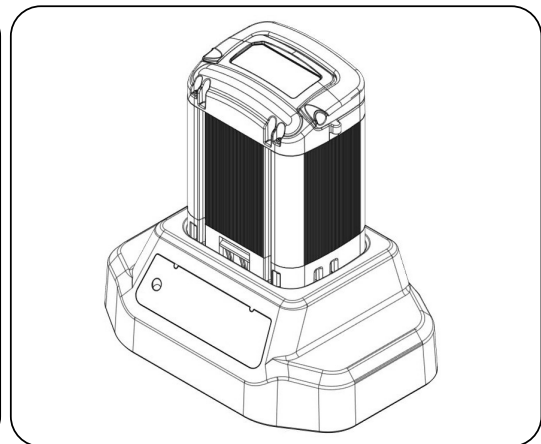
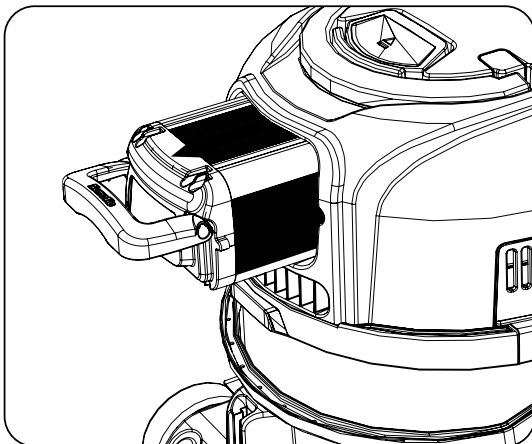
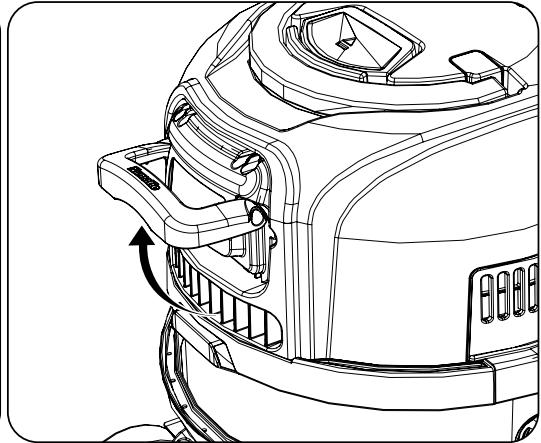
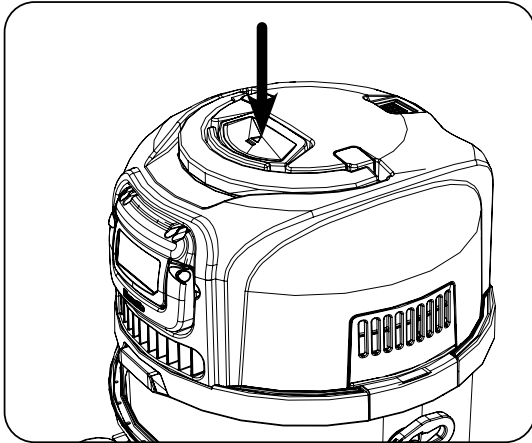

For information relating to the operation and charging of your battery refer to the battery and charger original operating instructions

Rating Label

1	Voltage / Direct Current
2	Rated input power
3	Weight (ready to work)
4	Company name & address
5	Model
6	Machine yr/wk Serial number
7	Approval Mark
8	Use Lithium-Ion Battery Only
9	IPX Rating

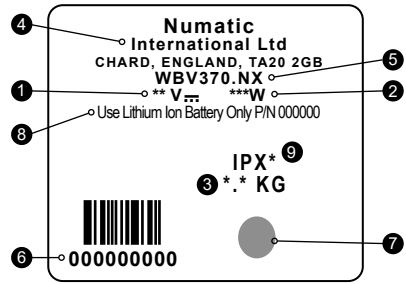

PPE (personal protective equipment) That may be required for certain operations.

Ear Protection	Safety Footwear	Head Protection	Safety Gloves	
Eye Protection	Protective Clothing	Dust / Allergens Protection	Hi Viz Jacket	
Note: A risk assessment should be conducted to determine which PPE should be worn.				

Failure to rectify the problem or in the event of a breakdown contact your Numatic dealer or the Numatic Technical helpline +44 (0)1460 269268

Daily

- Keep the machine clean, including hoses and tubes.
- Ensure the bag and filter are fitted.
- Regularly examine the charger.
- Check dust bag frequently.
- Check filters are clean.

Weekly - as daily and:-

- Check for any worn or damaged parts and replace immediately.
- Do not steam clean or pressure wash.

Batteries

- Always recharge the batteries after use.

MAINTENANCE

Safety Critical Components

Multi-Regional Charger 911334 (100-240V ~ 50/60 Hz)

Lithium- Ion Battery 8.1 Ah

Warning

Read the instruction manual before using the machine.

Operators shall be adequately instructed on the use of these machines.

As with all electrical equipment, care and attention must be exercised at all times during use, in addition to ensuring that routine and preventative maintenance is carried out periodically to ensure safe operation.

Failure to carry out maintenance as necessary, including the replacement of parts to the correct standard could render this equipment unsafe and the manufacturer can accept no responsibility in this respect.

The machine shall be switched off and the battery removed before cleaning or maintenance and when replacing parts or converting the machine to another function.

This machine is not to be used by children or persons with reduced physical, sensory or mental capabilities, or lack of experience or knowledge.

Children being supervised are NOT to play with the machine. This appliance is intended to be assembled, cleaned and maintained by an adult. This machine is not a toy. This machine is not suitable for picking up hazardous or explosive dust. Contact your local distributor if you require a machine capable of performing these tasks.

Caution

If foam/liquid comes out of machine exhaust, switch off immediately.

Allow the accumulated liquid to drain out through the machine exhaust, check the float assembly to ensure correct operation, empty the container if full of liquid, reassemble the machine.

Immediately upon start up there will be a certain amount of liquid issuing from the machine exhaust which will be the residue of liquid still within the power head. This will be quickly discharged after which the machine should function normally. Liquid ejected from the machine could be hazardous as a result of its temperature, pressure or chemical content.

Ensure that the filtration system fitted to the machine is suitable for the material being collected.

This machine is for indoor use only. This machine shall be stored indoors only.

When moving from one place to another, consider the weight of the machine.

Notes

This product complies with the requirements of clause 20 of IEC/EN 60335-2-69 Stability and Mechanical Hazards.

The primary use for this machine is commercial, for example in hotels, schools, hospitals, factories, shops and offices.

If the vacuum cleaner stops working, remove the battery before investigating where the fault lies.

The vacuum cleaner should be inspected after use for damage.

Do

- Use a bag and filter at all times when using 'dry'.
- Keep your machine clean.
- Keep filters clean.
- Regularly clean the water level limiting float safety valve and examine for signs of damage or correct operation.
- Keep hoses and tubes clear.
- Replace any worn or damaged parts immediately.
- Wet filters and the interior part of the liquid container shall be dried before storage.

Don't

- Use steam cleaners or pressure washers to clean the machine or use the machine in the rain.
- Immerse in water for cleaning.
- Allow any inexperienced repairs. Call the experts.
- Use wet if float valve is not functioning or fitted.
- Use to suck up hot ashes, or lighted cigarette ends.
- Walk over-wet carpets, upholstery or fabrics.
- Walk on clean carpets until fully dry.
- Attempt machine maintenance or cleaning unless the battery has been removed from the machine head.
- Under any circumstances place foreign objects including (but not limited to) air fresheners, air freshener capsules or scented beads of any type into the top filter of the machine. Doing so can be dangerous and risk damage to the machine and may invalidate the machine warranty.

Fault Finding

Dry Mode maintenance/fault finding

If the vacuum cleaner stops working switch off and remove the battery before investigating where the fault lies.

If the vacuum cleaner will not pick up any debris from the surface, switch off and remove the battery, inspect the floor tool, wands and hose for blockages, if no blockages are found, the dust bag may be full if the dust bag is not full the filter may be blocked.

Wet mode

If the vacuum cleaner stops working switch off and remove the battery before investigating where the fault lies.

If the vacuum cleaner has a blockage and will not pick up liquid, switch off and remove the battery. Has the float valve operated?, this will shut off the suction and the pitch of the vacuum motor will change.

Remove the power head and empty the liquid out of the container, if the container is empty, check that the floor tool wands and hose are not blocked.

Flush the system with clean water after use.

After use always inspect the machine for damage.

Motor Power	Max Airflow (Motor Only)	Max Pressure (Motor Only)	Max Airflow (In Product w/kit)	Max Pressure (In Product w/kit)
400W	49 L/sec	145 mBar	22 L/sec	120 mBar
Run Time	Sound Pressure (LpA)	Sound Pressure Uncertainty (KpA)	Sound Power (LwA)	Sound Power Uncertainty (KwA)
40 min	78 dB(A)	2 dB	86 dB(A)	2 dB
Capacity (Wet)	Capacity (Dry)	Size	Weight	IPX Rating
6L	9L	480 x 360 x 375mm	9.3 Kg	IPX4

Recommended Spares

604016	370 / 380 (NVM 2BH) Pack of 10 bags	604165	TriTex Filter
--------	-------------------------------------	--------	---------------

Schematic

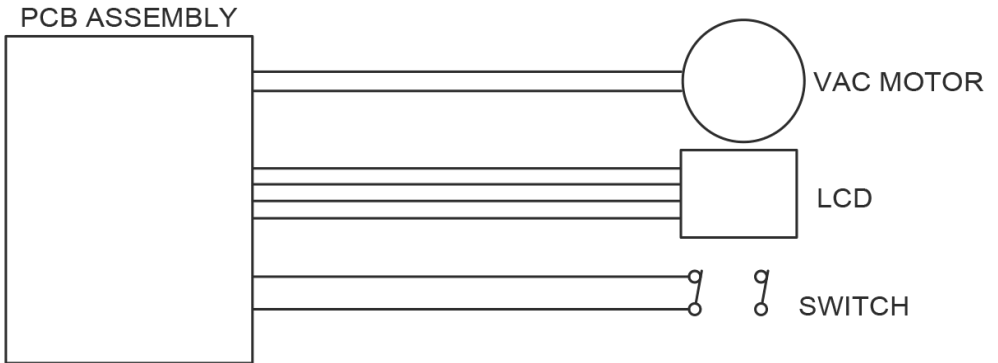

Numatic Lithium-ion Rechargeable Battery

36V | 8400mAh | 300Wh | 10INR19/65-3



It is important that you observe the following information and warnings!

FR – Gardez la batterie au sec

Il est important que vous respectiez les instructions et mises en garde suivantes!

Emergency Contact Information

Address:	CBAK BATTERY HEADQUARTERS Shenzhen BAK ENERGY Co. LTD, 2603A BAK Tech Bldg, 9th Keyan Rd, Hi-tech Park, Nanshan Dist, Shenzhen City, China	NUMATIC INTERNATIONAL LTD Millfield Road, Chard, Somerset, TA20 2GB, UK
Tel:	0086-755-83283710	0044-146-068600
www.numatic.co.uk www.numatic.de www.numatic.ch www.numatic.fr www.numatic.nl www.numatic.co.za www.numatic.pt www.numatic.es www.numatic-online.dk		

1. DEFECTIVE BATTERIES

GB

1. If a customer wishes to return a battery to a supplier, then collection of the battery must be arranged by the supplier; however. **Faulty batteries must not be returned through the postal system or by courier.**
2. If on return to a supplier, OR at a customer base, a suspected defective battery shows any signs of impact damage, distortion, blistering, loose parts, liquid ingress or leakage then on no account should it be offered for condition checking. It must be considered defective and the procedures described from item 9 below should be followed.
3. If, on return to a supplier, OR at a customer base, a suspected defective battery, that shows No signs of impact damage, distortion, blistering, loose parts, liquid ingress or leakage, may be offered for condition checking with an appropriate battery condition checking device operated by a competent person.
4. If battery is subjected to any liquid ingress users should put the pack upright immediately, with the terminal face downwards.
5. If checking shows the battery to be defective then the procedures described from item 9 below should be followed.
6. If on checking the battery is found to be operational then a single recharge cycle under observation can be attempted with the appropriate Numatic charger.
7. If the battery recharges correctly on this single recharge cycle then it can be deemed a good battery.
8. If the battery fails to recharge correctly on this single recharge cycle then it must be deemed a defective battery and the procedures described from item 9 below should be followed. **On no account must any further attempt to recharge be made. A defective battery should not be stored inside buildings on any account.**

9. The defective battery should be discharged by placing it in a container of salt water located in a well- ventilated area. This container should contain 25 litres minimum of saline water at a concentration of 15g common salt / litre of water. The container should have a closed locked lid but should not be sealed. The battery should be left fully immersed in the water to a depth of at least 100mm for at least 2 weeks. The water should be disposed of as hazardous waste when the discharge is complete.
10. The defective discharged battery can then be stored in a locked battery waste container which should be plastic or plastic lined and placed away from buildings and clearly signed as a defective battery container with appropriate warnings.
11. The batteries should then be sent for waste disposal according with your country's waste regulations.

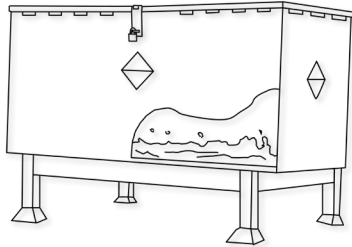

An example of a waste battery storage bin well away from buildings.

2. HANDLING AND STORAGE

GB

DANGER!

Improper handling can lead to an explosion or ignite a fire!
Store batteries out of reach of children.

- Insert the battery in the appliance only when it is in use.
- Always remove the battery from the appliance for transport and when it is not in use.
- Storage temperature range: -10°C~55°C.
- Temperatures must not exceed 55°C.
- Relative humidity range: 45 to 80%.
- Optimum preservation of functionality: 15°C~25°C.

WARNING:

- Do not open the battery, disassemble it or allow it to fall from a substantial height.
- Protect the battery against short-circuiting – danger of explosion!
- Protect the battery against rain, do not immerse in liquids especially flammable liquids – danger of short-circuiting potential risk of fire or explosion. Follow defective battery disposal safety procedure. Insure the product is moved away from any combustible source.
- Protect the battery against direct sunlight, heat and fire.
- Do not incinerate the battery – danger of explosion!
- Do not use defective or deformed batteries.
- Use only original NUMATIC chargers to charge the battery.

STORAGE:

- Good batteries should be stored in a protected area away from sources of direct heat and sunlight and should be kept dry.
- The temperature should not exceed 55°C but preferably not be above 25°C to maintain good battery performance.
- Storage area should be of low humidity, non dusty and a non corrosive atmosphere.

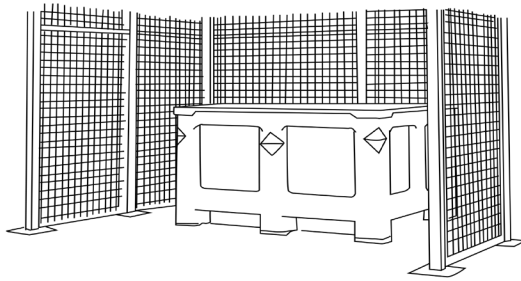

- An example of a well protected area with a cage to protect against accidental impact damage and with the batteries stored in a protective container to protect from heat, impact and accidental spillage of liquids.
- Care when handling / moving with forklift trucks or pallet trucks is needed at all times to avoid any physical damage to the batteries.
- If a good battery at any time is mishandled or subjected to any conditions that may damage it, as described in the battery Instruction manual supplied, it must then be considered as defective and procedures followed from Item 1 of this document overleaf.

3. HAZARDS IDENTIFICATION

GB

- Electrolyte may escape from damaged batteries. Avoid contact.
- Contact can cause skin irritation, burns and chemical burns.
- If liquid comes into contact with eyes, seek medical attention.
- Avoid inhaling any vapours formed or released – caustic.

4. FIRST AID MEASURES

GB

In the event of contact with released electrolyte or electrolyte vapours:

- Eye contact – flush eyes for at least 15 minutes with plenty of clean water without rubbing and seek medical attention.
- Skin contact – wash affected areas of skin with plenty of water and soap; if irritation persists, seek medical attention.
- Inhalation – provide fresh air or administer oxygen immediately and seek medical attention.
- Ingestion – if electrolyte has been ingested, seek medical attention immediately.

Information for physicians:

- Contains caustic alkaline electrolytes in cells with lithium oxide, nickel oxide and cobalt/lithium manganese oxide cathodes – NO LITHIUM METAL OR LITHIUM ALLOYS.

5. FIRE FIGHTING MEASURES

GB

- In case of fire – Keep clear of vapours and gases generated, take wind direction into consideration. If possible without danger, remove batteries from the vicinity of the fire. In principle, cooling or extinguishing with water is possible, but should only be done by trained personnel with sufficiently large quantities of water.
- If the hazard situation is unclear, extinguish only with ABC powder extinguishers (Class D extinguishers for fires involving metals are especially suitable).
- Fire fighters should only approach the fire wearing protective clothing and self-contained breathing apparatus.
- Once the fire has been extinguished, as a rule, the area should be monitored (fire watch) and cleaned up by trained and appropriately equipped personnel; fire residue should be contained and disposed of properly.

6. ACCIDENTAL RELEASE

GB

Disposal – Wear protective gear, wipe up with absorbent textile and dispose of as hazardous waste at collection points for hazardous waste according to national regulations.

7. EXPOSURE CONTROLS, PERSONAL PROTECTION

GB

Respiratory Protection:

- In case of battery venting, providing as much ventilation as possible. Avoid confined areas with venting batteries.
- Respiratory Protection is not necessary under conditions of normal use.

Ventilation:

- Not necessary under conditions of normal use.

Protective Gloves:

- Not necessary under conditions of normal use.

Other Protective Clothing or Equipment:

- Not necessary under conditions of normal use.
- Personal Protection is recommended for venting batteries: Respiratory Protection, Protective Gloves, Protective Clothing and safety glass with side shields.

8. DO

GB

- Use NUMATIC batteries only with NUMATIC appliances and charge them only using NUMATIC chargers.
- Charge battery before use.
- Store the battery out of the reach of children.
- Secure the appliance against unintentional start up – remove the battery from the appliance before transporting or storing the appliance.
- Protect from rain and liquid ingress
- Protect from direct sunlight, heat, and open flames.
- Keep a battery that is not in use away from metal objects, (e.g. nails, coins, jewellery).
- Follow the disposal advice of the manufacturer and any internal waste management guidance.
- Use and store the battery with-in temperature range (as shown in Temperature Range Table).

Warning: The battery included in this product must only be charged by the Numatic Charger and docking system supplied with the product and in NO circumstances should an alternative non Numatic charger be used as there is risk severe damage and fire could result.

Note* “If batteries are subjected to temperatures beyond normal operating limits automatic shutdown will occur. Under these conditions allow the batteries to acclimatise at room temperature (18°C – 22°C) for several hours to allow the battery to wake up”.

Temperature Range Table	
CHARGING	5°C~35°C
DISCHARGING	5°C~35°C
STORAGE OPTIMUM	15°C~25°C
STORAGE LIMIT	-10°C~55°C

Warranty

Numatic International Limited warrant to the original purchaser that its products are free of defects in both material and workmanship for the period shown below:-

- Homecare and Procare Vacuum cleaners..... 2 Years**
- Rotary Floor Machines..... 1 Year**
- Twintec Auto Scrubber Dryer..... 1 Year**
- Vario Ride-On Scrubber Dryer..... 1 Year / 1500 hours**
- Mopping, Compacts, Versaclean and Versacare Products..... 1 Year**
- Individual Accessories and Spare Parts..... 6 Months**

Note: This warranty expressly excludes consumable parts such as carbon brushes, floor brushes, mops, batteries etc, that are considered replaceable from time to time during the normal working life of the machine.

Our goods come with guarantees that cannot be excluded under the Australian Consumer Law. You are entitled to a replacement or refund for a major failure and for compensation for any other reasonably foreseeable loss or damage. You are also entitled to have the goods repaired or replaced if the goods fail to be of acceptable quality and the failure does not amount to a major failure.

The benefits under (Our Warranty) are in addition to other rights and remedies under a law in relation to the (goods/services)

- A. The warranty period commences from the date the goods are purchased. We advise all purchasers to retain their invoice as proof of purchase.
- B. All warranty claims must be processed through either the Dealer from whom the equipment was originally purchased or another authorised Edgar Edmondson Pty Ltd Australia dealer. The Dealer will co-operate with the purchaser throughout the warranty claims procedure and will arrange any necessary repairs using genuine Numatic parts.
- C. If the original Dealer is no longer able to fulfil his obligations please contact Edgar Edmondson Pty Ltd Australia with full details of the claim and proof of purchase so that this may be processed without delay.
- D. Any warranty claim can only relate to the specific part that is proven to be at fault and for which a replacement will be supplied but cannot be extended to constitute a claim against the complete machine.
- E. Edgar Edmondson Pty Ltd Australia will supply the Dealer with any warranty parts required, subject to the claim being validated.
- F. Claims will not be accepted if they are the result of fair wear and tear, misuse or abuse of any kind.
- G. No replacement will be given unless the appropriate evidence of the validity of the claim has been provided to the satisfaction of Edgar Edmondson Pty Ltd Australia.
- H. Edgar Edmondson Pty Ltd Australia reserve the right to charge for any work carried out as a result of an invalid claim.
- I. No variation to this warranty may be made or implied by any member of Edgar Edmondson Pty Ltd Australia or its Dealers unless such variation is in writing and authorised by the Company.

Australian Importer.

Edgar Edmondson Pty Ltd

Head Office Delivery and Shipping Address
PO Box 198 18 Garden St
Marrickville Marrickville
NSW 1475 NSW 2204
AUSTRALIA AUSTRALIA

Office Number: 1800 BU'Y MOP
Fax Number: +61 (0)2 9519 9223
E-Mail: orders@edmondson.net.au
ABN: 27 000 450 144

Edco

Notes:

Numatic

Distributed by:-

Edgar Edmondson Pty Ltd

Head Office	Delivery and Shipping Address	Office Number: 1800 BUY MOP
PO Box 198	18 Garden St	Fax Number: +61 (0)2 9519 9223
Marrickville	Marrickville	E-Mail: orders@edmondson.net.au
NSW 1475	NSW 2204	
AUSTRALIA	AUSTRALIA	ABN: 27 000 450 144

Edco

Numatic International Limited.
Chard, Somerset TA20 2GB ENGLAND
Tel: 01460 68600 www.numatic.co.uk

UNITED KINGDOM: www.numatic.com GERMANY: www.numatic.de SWITZERLAND: www.numatic.ch
FRANCE: www.numatic.fr NETHERLANDS: www.numatic.nl SOUTH AFRICA: www.numatic.co.za
PORTUGAL: www.numatic.pt SPAIN: www.numatic.es DENMARK: www.numatic-online.dk

Specification subject to change without prior notice
www.numatic.com © Numatic International Limited

916733 05/23 (A01)